



**IMPORTANT!
DO NOT DESTROY**

Installation and Maintenance Manual

with **Safety Information**
and **Parts List**

RECOMMENDED SPARE PARTS HIGHLIGHTED IN GRAY

Model PCH

Effective March, 1995
(Supercedes November, 1993)

Bulletin #429



HYTROL CONVEYOR CO., INC.

Jonesboro, Arkansas
St. Louis, Missouri
Manteca, California

● Table of Contents

Warning Signs2

INTRODUCTION

Receiving and Uncrating3

INSTALLATION

Installation Safety Precautions3

Conveyor Set-Up4-5

Belt Installation6-7

Electrical Equipment8

OPERATION

Operation Safety Precautions9

Conveyor Start-Up9

MAINTENANCE

Maintenance Safety Precautions10

Lubrication10

Drive Chain Alignment and Tension11

Trouble Shooting12

Preventive Maintenance Checklist13

REPLACEMENT PARTS

How To Order Replacement Parts13

Model PCH Parts Drawing14

Model PCH Parts List15

● Warning Signs

In an effort to reduce the possibility of injury to personnel working around HYTROL conveying equipment, warning signs are placed at various points on the equipment to alert them of potential dangers. Please check equipment and note

all warning signs. Make certain your personnel are alerted to and obey these warnings. Shown below are typical signs that are attached to this equipment.



PLACED ON ALL POWERED CONVEYORS NEAR DRIVE AND/OR CONTROLS.



PLACED NEXT TO DRIVE, BOTH SIDES.



PLACED ON 20 FT. INTERVALS, BOTH SIDES.



PLACED ON TERMINATING ENDS.



PLACED ON ALL CHAIN GUARDS.



PLACED AT DRIVE OF ALL POWERED CONVEYORS.

INTRODUCTION



This manual provides guidelines and procedures for installing, operating, and maintaining your conveyor. A complete parts list is provided with recommended spare parts highlighted in gray. Important safety information is also provided throughout

the manual. For safety to personnel and for proper operation of your conveyor, it is recommended that you read and follow the instructions provided in this manual.

● Receiving and Uncrating

1. . . Check the number of items received against the bill of lading.
2. . . Examine condition of equipment to determine if any damage occurred during shipment.
3. . . Move all crates to area of installation.
4. . . Remove crating and check for optional equipment that may be fastened to the conveyor. Make sure these parts (or any foreign pieces) are removed.

NOTE: If damage has occurred or freight is missing, see the “Important Notice” attached to the crate.

INSTALLATION

● Installation Safety Precautions *for Conveyors and Related Equipment*

GUARDS AND GUARDING

Interfacing of Equipment. When two or more pieces of equipment are interfaced, special attention shall be given to the interfaced area to insure the presence of adequate guarding and safety devices.

Guarding Exceptions. Wherever conditions prevail that would require guarding under these standards, but such guarding would render the conveyor unusable, prominent warning means shall be provided in the area or on the equipment in lieu of guarding.

Guarded by Location or Position. Where necessary for the protection of employees from hazards, all exposed moving machinery parts that present a hazard to employees at their work station shall be mechanically or electrically guarded, or guarded by location or position.

When a conveyor passes over a walkway, roadway, or work station, it is considered guarded solely by location or position if all moving parts are at least 8 ft. (2.44 m) above the floor or walking surface or are otherwise located so that the employee cannot inadvertently come in contact with hazardous moving parts.

Although overhead conveyors may be guarded by location, spill guard, pan guards, or equivalent shall be provided if the product may fall off the conveyor for any reason and if personnel would be endangered.

HEADROOM

When conveyors are installed above exit passageways, aisles, or corridors, there shall be provided a minimum clearance of 6 ft. 8 in. (2.032 m) measured vertically from the floor or walking surface to the lowest part of the conveyor or guards. Where system function will be impaired by providing the minimum clearance of 6 ft. 8 in. (2.032 m) through an emergency exit, alternate passageways shall be provided.

It is permissible to allow passage under conveyors with less than 6 ft. 8 in. (2.032 m) clearance from the floor for other than emergency exits if a suitable warning indicates low headroom.

● Conveyor Set-Up

- 1... Determine direction of product flow. Figure 4A indicates the flow as related to the drive.
- 2... Position conveyor in area of installation. **NOTE:** *If conveyor is shipped in more than one piece, position the conveyor sections in sequence with the match-marked numbers at each end. (Figure 5B).*
- 3... Mark a chalk line on the floor to locate center of the conveyor.
- 4... *If conveyor is shipped in one piece—attach supports as shown in Figures 4A, 5A, or 5B. If conveyor is shipped in more than one piece—fasten sections together with butt couplings and support mounting plates. (Figure 5C). NOTE: The lower belt track is bolted to the lower flange through a series of trapped holes. To install supports, some of these bolts have*
to be removed and reinstalled through the support pivot plates. Since the track is bolted to the frame with these bolts, care must be taken not to lose the track when bolts are removed. Only remove the bolts needed to install the support. The bolts are on 6" centers where supports are located.
- 5... Place conveyor in its operating position. Check to see that it is level and is not twisted. Adjust supports and lag to floor.
- 6... Install electrical controls and wire motor. See Page 8.
- 7... Install belt (if shipped separately) per instructions on page 6.

FIGURE 4A

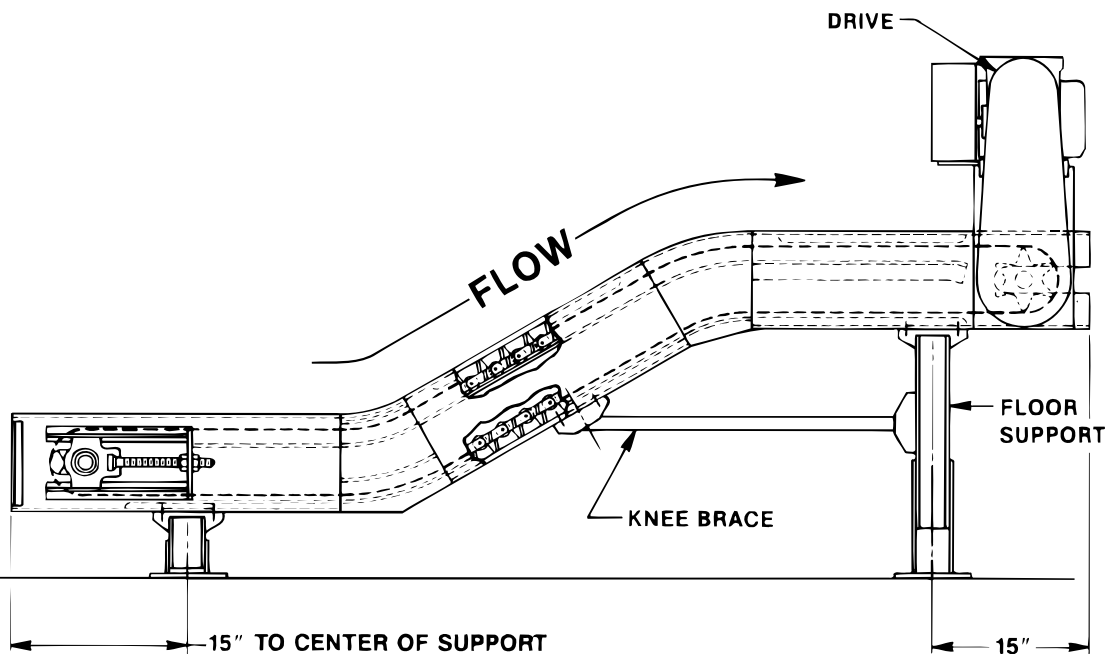

● Conveyor Setup (Continued)

FIGURE 5A

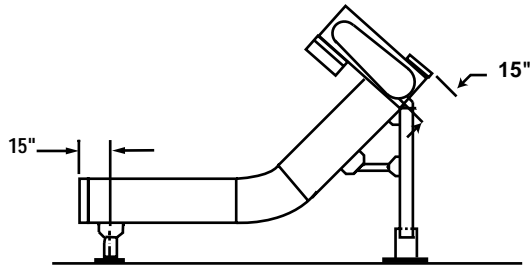

FIGURE 5B

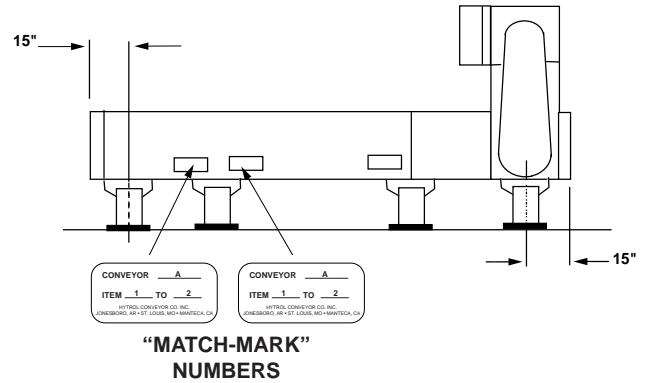
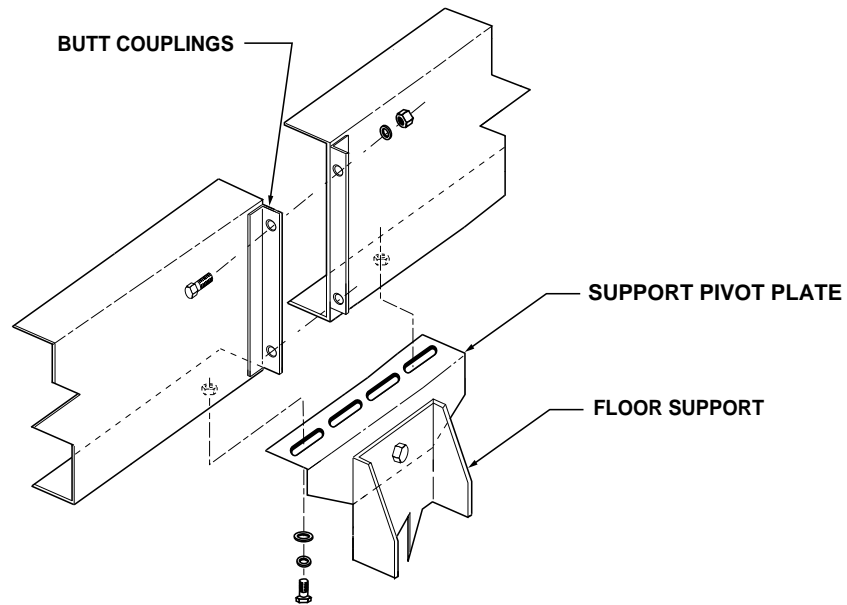

FIGURE 5C



● Belt Installation

1. . . Remove chain guard and drive chain to allow drive sprockets to turn freely during belt installation. (Figure 7A).
2. . . Remove end cap. (Figure 7B).
3. . . Determine belt's direction of travel by markings on the belt wings. (Figure 7A).
4. . . Loosen drive mounting bolts and drive takeup bolts and move drive away from discharge end (toward tail end) as far as it will go. Check to see that both sides are an equal distance from end and retighten bolts. **NOTE:** *This take-up will be used to adjust belt tension after conveyor is in operation.*
5. . . Loosen take-up bolts at tail end so that belt connecting pin may be inserted through end of take-up slot. (Figure 7B).
6. . . Start belt in at take-up end, pulling it over top of sprockets and up through belt track. Belt wing guides in the conveyor frame help to center the belt. (Figure 7A).
7. . . Pull belt over drive sprockets and feed back into return belt track.
8. . . Pull belt down return track to tail sprockets. Hold ends of belt around sprockets and insert connecting pin through take-up slot. (Figure 7B).
9. . . Replace drive chain, chain guard, and end cap that were removed in Steps 1 & 2 above.
10. . . Adjust belt tension with take-up bolts at tail shaft. Keep shaft square by moving both take-up bolts an equal amount. (Figures 7A & 7B).

NOTES

- A) **BELTS ALLOWED TO OPERATE WITH TOO MUCH TENSION** is usually indicated by pulsation or surge and will cause excessive wear on pins and chain side bar joints thereby greatly reducing belt life and causing excessive wear to sprockets.
- B) **BELTS ALLOWED TO OPERATE WITH INSUFFICIENT TENSION** is usually indicated by the downward flexing of hinged joint at point where belt disengages from tail shaft sprockets and at the point just prior to engaging with drive shaft sprockets. Belt may run to one side of conveyor causing excessive wear to side wings and sides of conveyor frame. A slight amount of wear on wings and skirts is normal because of close tolerances maintained in frame construction.
- C) Hinged metal belts will require a take-up adjustment after approximately 30 days run-in and periodically thereafter.
- D) Periodic lubrication of belts, hinge pins, rollers, and side wings is recommended to extend belt life.

● Belt Installation (Continued)

FIGURE 7A

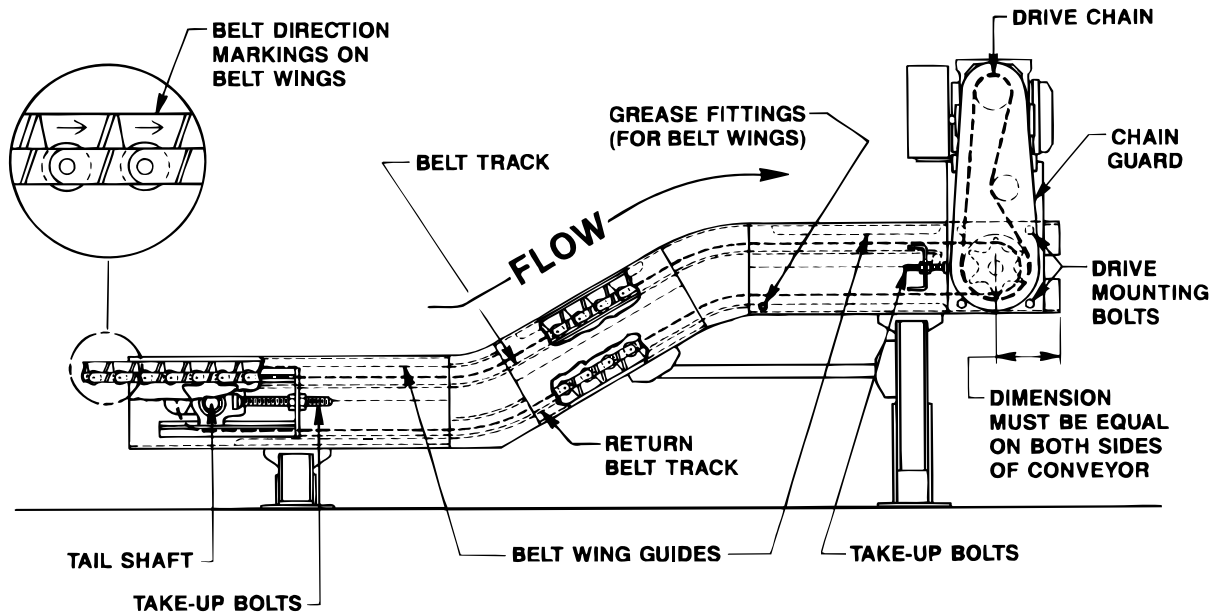

FIGURE 7B

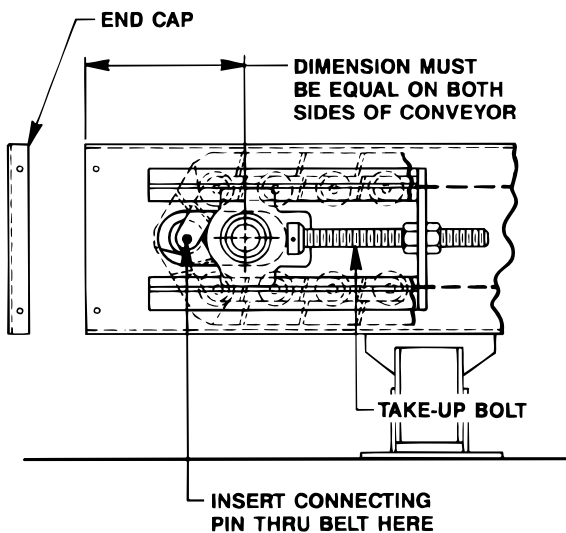
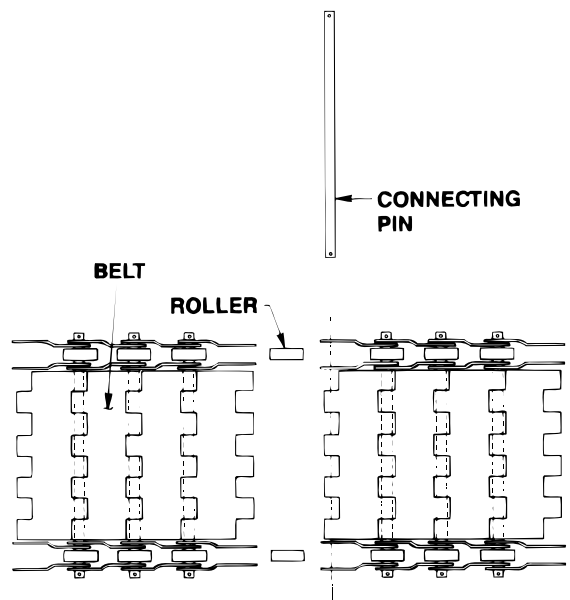

FIGURE 7C



● Electrical Equipment

WARNING!

Electrical controls shall be installed and wired by a qualified electrician. Wiring information for the motor and controls are furnished by the equipment manufacturer.

CONTROLS

Electrical Code: All motor controls and wiring shall conform to the National Electrical Code (Article 670 or other applicable articles) as published by the National Fire Protection Association and as approved by the American Standards Institute, Inc.

CONTROL STATIONS

A) Control stations should be so arranged and located that the operation of the equipment is visible from them, and shall be clearly marked or labeled to indicate the function controlled.

B) A conveyor which would cause injury when started shall not be started until employees in the area are alerted by a signal or by a designated person that the conveyor is about to start.

When a conveyor would cause injury when started and is automatically controlled or must be controlled from a remote location, an audible device shall be provided which can be clearly heard at all points along the conveyor where personnel may be present. The warning device shall be actuated by the controller device starting the conveyor and shall continue for a required period of time before the conveyor starts. A flashing light or similar visual warning may be used in conjunction with or in place of the audible device if more effective in particular circumstances.

Where system function would be seriously hindered or adversely affected by the required time delay or where the intent of the warning may be misinterpreted (i.e., a work area with many different conveyors and allied devices), clear, concise, and legible warning shall be provided. The warning shall indicate that conveyors and allied equipment may be started at any time, that danger exists, and that personnel must keep clear. The warnings shall be provided along the conveyor at areas not guarded by position or location.

C) Remotely and automatically controlled conveyors, and conveyors where operator stations are not manned

or are beyond voice and visual contact from drive areas, loading areas, transfer points, and other potentially hazardous locations on the conveyor path not guarded by location, position, or guards, shall be furnished with emergency stop buttons, pull cords, limit switches, or similar emergency stop devices.

All such emergency stop devices shall be easily identifiable in the immediate vicinity of such locations unless guarded by location, position, or guards. Where the design, function, and operation of such conveyor clearly is not hazardous to personnel, an emergency stop device is not required.

The emergency stop device shall act directly on the control of the conveyor concerned and shall not depend on the stopping of any other equipment. The emergency stop devices shall be installed so that they cannot be overridden from other locations.

D) Inactive and unused actuators, controllers, and wiring should be removed from control stations and panel boards, together with obsolete diagrams, indicators, control labels, and other material which serve to confuse the operator.

SAFETY DEVICES

A) All safety devices, including wiring of electrical safety devices, shall be arranged to operate in a "Fail-Safe" manner, that is, if power failure or failure of the device itself would occur, a hazardous condition must not result.

B) *Emergency Stops and Restarts.* Conveyor controls shall be so arranged that, in case of emergency stop, manual reset or start at the location where the emergency stop was initiated, shall be required of the conveyor(s) and associated equipment to resume operation.

C) Before restarting a conveyor which has been stopped because of an emergency, an inspection of the conveyor shall be made and the cause of the stoppage determined. The starting device shall be locked out before any attempt is made to remove the cause of stoppage, unless operation is necessary to determine the cause or to safely remove the stoppage.

Refer to ANSI Z244.1-1982, American National Standard for Personnel Protection – Lockout/Tagout of Energy Sources – Minimum Safety Requirements and OSHA Standard Number 29 CFR 1910.147 "The Control of Hazardous Energy (Lockout/Tagout)."

● Operation Safety Precautions

A) Only trained employees shall be permitted to operate conveyors. Training shall include instruction in operation under normal conditions and emergency situations.

B) Where employee safety is dependent upon stopping and/or starting devices, they shall be kept free of obstructions to permit ready access.

C) The area around loading and unloading points shall be kept clear of obstructions which could endanger personnel.

D) No person shall ride the load-carrying element of a conveyor under any circumstances unless that person is specifically authorized by the owner or employer to do so. Under those circumstances, such employee shall only ride a conveyor which incorporates within its supporting structure, platforms or control stations specifically designed for carrying personnel. Under no circumstances shall any person ride on any element of a vertical conveyor. Owners of conveyors should affix warning devices to the conveyor reading **Do Not Ride Conveyor**.

E) Personnel working on or near a conveyor shall be instructed as to the location and operation of pertinent stopping devices.

F) A conveyor shall be used to transport only material it is capable of handling safely.

G) Under no circumstances shall the safety characteristics of the conveyor be altered if such alterations would endanger personnel.

H) Routine inspections and preventive and corrective maintenance programs shall be conducted to insure that all safety features and devices are retained and function properly.

I) Personnel should be alerted to the potential hazard of entanglement in conveyors caused by items such as long hair, loose clothing, and jewelry.

J) As a general rule, conveyors should not be cleaned while in operation. Where proper cleaning requires the conveyor to be in motion and a hazard exists, personnel should be made aware of the associated hazard.

● Conveyor Start-Up

Before conveyor is turned on, check for foreign objects that may have been left inside conveyor during installation. These objects could cause serious damage during start-up.

After conveyor has been turned on and is operating, check motors, reducers, and moving parts to make sure they are working freely.

CAUTION!

Because of the many moving parts on the conveyor, all personnel in the area of the conveyor need to be warned that the conveyor is about to be started.

● Maintenance Safety Precautions

- A) Maintenance, such as lubrication and adjustments, shall be performed only by qualified and trained personnel.
- B) It is Important that a maintenance program be established to insure that all conveyor components are maintained in a condition which does not constitute a hazard to personnel.
- C) When a conveyor is stopped for maintenance purposes, starting devices or powered accessories shall be locked or tagged out in accordance with a formalized procedure designed to protect all person or groups involved with the conveyor against an unexpected start.
- D) Replace all safety devices and guards before starting equipment for normal operation.

E) Whenever practical, **DO NOT** lubricate conveyors while they are in motion. Only trained personnel who are aware of the hazard of the conveyor in motion shall be allowed to lubricate.

SAFETY GUARDS

Maintain all guards and safety devices **IN POSITION** and **IN SAFE REPAIR**.

WARNING SIGNS

Maintain all warning signs in a legible condition and obey all warnings. See Page 2 of this manual for examples of warning signs.

● Lubrication

BEARINGS

STANDARD: Supplied sealed and pre-lubricated. No lubrication required.

BELT

To extend belt life, it is recommended that the hinge pins and rollers be lubricated with SAE-30 wt. oil and that the belt wings be greased with a good grade of bearing grease approximately every 40 hours of operation. **NOTE:** *To apply grease to the belt wings, grease fittings have been installed through the conveyor frame and lower belt track of the drive section (See Figure 7A). To grease, it is necessary for the conveyor to be running. Pump grease slowly so the belt wings will pick it up and distribute around the belt guides. Apply to both sides until grease has been distributed the full length of belt.*

CHAIN

It is recommended that the drive chain be lubricated with SAE-30 oil approximately every 40 hours of operation. Under extreme conditions, more frequent lubrication may be required. (Also, See "Drive Chain Alignment and Tension").

REDUCERS

MANUFACTURED BY HYTROL: See separate manual in Packing Envelope that contains lubrication and maintenance instructions for HYTROL's Gear Reducer.

MANUFACTURED BY OTHERS: Refer to their recommendations.

CAUTION!

Only trained personnel who are aware of the hazard of the conveyor in motion shall be allowed to lubricate.

● Drive Chain Alignment and Tension

The drive chain and sprockets should be checked periodically for proper tension and alignment. Improper adjustment will cause extensive wear to the drive components.

TO MAKE ADJUSTMENTS

1. . . Remove chain guard.
2. . . Check sprocket alignment by placing a straightedge across the face of both sprockets. (Figure 11A.) Loosen set screws and adjust as needed. Retighten set screws.
3. . . To adjust tension, loosen idler mounting bolt and move idler until slack is removed from chain (Figure 11B). Retighten mounting bolts.
4. . . Lubricate chain per lubrication instructions.
5. . . Replace chain guard so that it does not interfere with drive.

FIGURE 11A

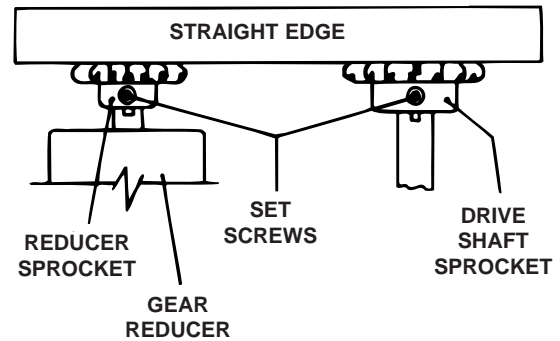
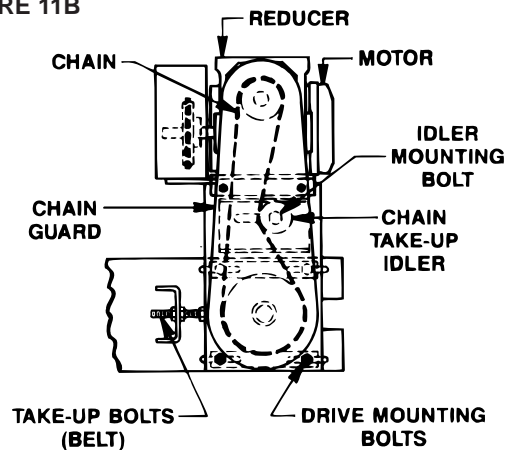

FIGURE 11B



CAUTION!!

Never remove chain guards while the conveyor is running. Always replace guards after adjustments are made.



● Trouble Shooting

TROUBLE SHOOTING DRIVES

TROUBLE	CAUSE	SOLUTION
Conveyor will not start or motor quits frequently.	1) Motor is overloaded or drawing too much current.	1) Check for overloading of conveyor. 2) Check heater or circuit breaker and change if necessary.
Drive chain and sprockets wear excessively.	1) Lack of lubrication on chain may have caused chain to stretch and created an improper chain to sprocket mesh. 2) Sprockets are out of alignment. 3) Loose chain.	1) Replace chain and sprockets. NOTE: If problem reoccurs, a chain take-up may be required. 2) Align sprockets. (See "Drive Chain Alignment and Tension"). 3) Tighten chain.
Loud popping or grinding noise.	1) Defective bearing. 2) Loose set screw. 3) Loose drive chain.	1) Replace bearing. 2) Tighten set screw. 3) Tighten chain.
Motor or reducer overheating.	1) Conveyor is overloaded. 2) Low voltage to motor. 3) Low lubricant level in reducer.	1) Check capacity of conveyor and reduce load to recommended level. 2) Have electrician check and correct as necessary. 3) Relubricate per manufacturer's recommendations. For HYTROL reducer, refer to separate manual

TROUBLE SHOOTING BELT

TROUBLE	CAUSE	SOLUTION
Belt dragging side of conveyor	1) Sprockets not set properly 2) Tail or drive shaft not square with conveyor frame 3) Conveyor twisted	1) Set sprockets so belt is centered in conveyor frame. 2) Adjust as necessary—(Both ends of shaft should be equal distance from end of bed). 3) Adjust supports.



● Preventive Maintenance Checklist

The following is a general maintenance checklist which covers the major components of your conveyor.

This will be helpful in establishing a standard maintenance schedule.

COMPONENT	SUGGESTED ACTION	SCHEDULE		
		Weekly	Monthly	Quarterly
MOTOR	Check Noise			
	Check Temperature			
	Check Mounting Bolts			
REDUCER	Check Noise			
	Check Temperature			
	Check Oil Level			
BELT	Check Tracking			
	Check Tension			
	Lubricate			
BEARINGS (Pulleys & Rollers)	Check Noise			
	Check Mounting Bolts			
DRIVE CHAIN	Check Tension			
	Lubricate			
	Check for Wear			
SPROCKETS	Check for Wear			
	Check Set Screws & Keys			
V-BELTS	Check Tension			
	Check for Wear			
	Check for Sheave Alignment			
STRUCTURAL	General Check: All loose bolts, etc., tightened			

● How to Order Replacement Parts

Included in this manual are parts drawings with complete replacement parts lists. Minor fasteners, such as nuts and bolts, are not included.

When ordering replacement parts:

1. . . Contact Dealer from whom conveyor was purchased or nearest HYTROL Distributor.
2. . . Give Conveyor Model Number and Serial Number or HYTROL Factory Order Number.
3. . . Give Part Number and complete description from Parts List.
4. . . If you are in a breakdown situation, tell us.



**HYTROL Serial Number
(Located near Drive
on Powered Models)**

● Model PCH Parts Drawing

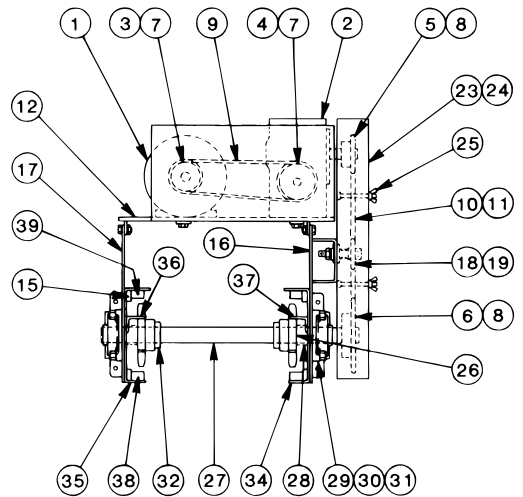
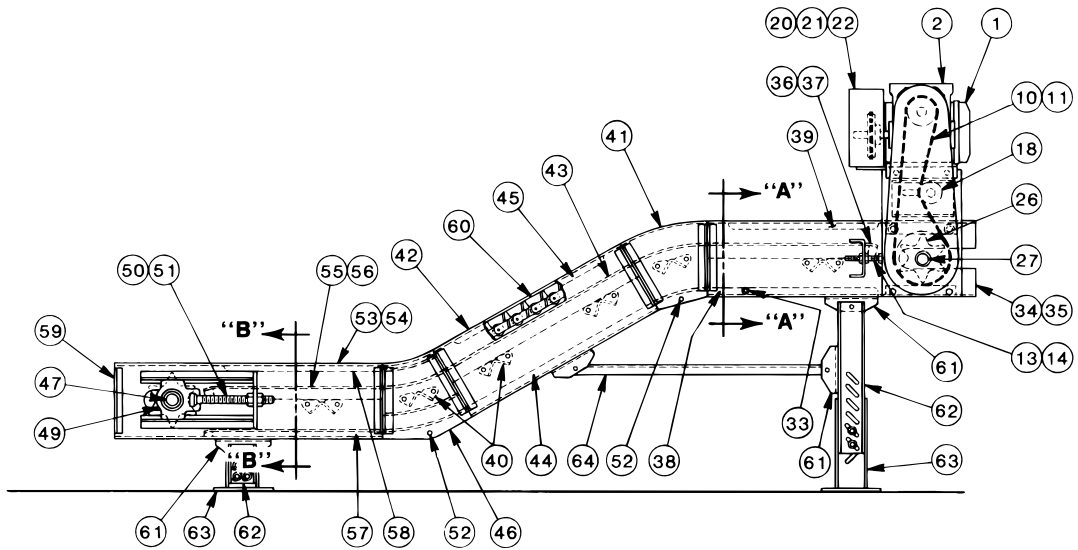

SECTION "A-A"

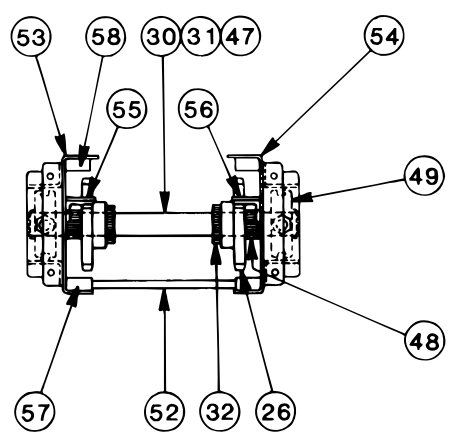

SECTION "B-B"

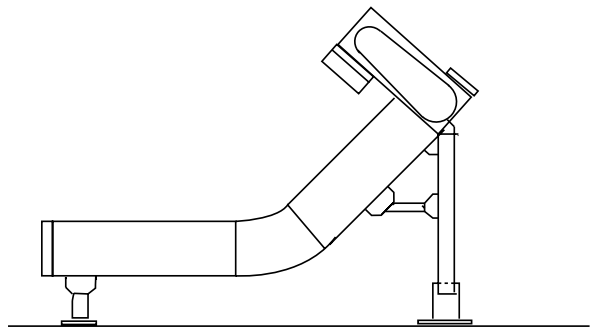
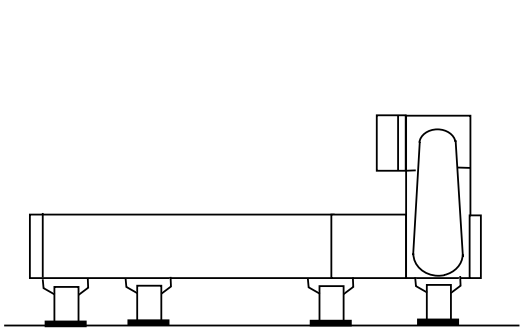

● Model PCH Parts List



Ref. No.	Part No.	Description
1	—	Motor—C-Face, Foot Mounted
—	030.7224	3/4 HP—230/460 VAC—3 Ph.—60 Hz.—TEFC
—	030.7324	1 HP—230/460 VAC—3 Ph.—60 Hz.—TEFC
—	030.7434	1 1/2 HP—230/460 VAC—3 Ph.—60 Hz.—TEFC
—	030.7534	2 HP—230/460 VAC—3 Ph.—60 Hz.—TEFC
2	—	Speed Reducer
—	R-00152-20R	4A—RH—20:1 Ratio
—	R-00163-20R	5A—RH—20:1 Ratio
3	—	Sheave—Motor, 2.5 in. Dia.
—	020.102	Single Groove—5/8 in. bore (3/4 HP)
—	021.100	Double Groove—5/8 in. Bore (1 HP)
—	021.111	Double Groove—7/8 in. Bore (1 1/2 - 2 HP)
4	—	Sheave—Reducer, 5 in. Dia.
—	020.120	Single Groove—3/4 in. Bore (3/4 HP)
—	021.107	Double Groove—3/4 in. Bore (1 - 2 HP)
5	—	Sprocket—Reducer
—	028.207	60B15 x 1 in. Bore (4A)
—	028.2071	60B15 x 1 1/4 in. Bore (5A)
6	028.2155	Sprocket—Drive Shaft, 60B26 x 1 7/16 in. Bore
7	090.202	Shaft Key—3/16 in. Square x 1 in. long
8	090.203	Shaft Key—1/4 in. Square x 1 in. long
9	—	V-Belt
—	066.109	4L310 (4A Reducer)
—	066.108	4L300 (5A Reducer)
10	029.102	#60 Riveted Roller Chain
11	029.202	Connector Link—#60 Riveted Roller Chain
12	B-6583	Motor Base Plate (Specify Belt Width)
13	040.5045	Take-up Bolt—5/8-11 x 4-1/2 in. Long
14	041.202	Hex Jam Nut—5/8-11
15	B-16642	Drive Adjustment Support Bar
16	B-16637	Drive Support Side Plate—RH
17	B-16638	Drive Support Side Plate—LH
18	028.637	Idler Sprocket—60BB10H x 5/8 in. Bore
19	B-16643	Spacer—7/8 in. O.D. x 5/8 in. I.D. x 7/8 in. Long
20	B-5120	V-Belt Guard—Inside
21	B-5119	V-Belt Guard—Outside
22	049.310	U-Type Speed Nut—1/4-20
23	B-16632	Chain Guard Front Plate
24	B-16635	Chain Guard Back Plate
25	049.552	Wing Nut 3/8-16
26	029.350	6-Tooth Sprocket
27	B-16644	Drive Shaft—1-7/16 in. Dia. (Specify Belt Width)
28	B-16645	Pulley Spacer—1.459 in. I.D. x 1-5/8 in. O.D. x 1-11/16 Lg
29	010.203	4-Bolt Flange Bearing—1-7/16 in. Bore
30	044.102	Set Screw—3/8-16 x 3/8 in. Long
31	090.204	Shaft Key—3/8 in. Square x 1 in. Long
32	098.189	Lock Collar—1-7/16 in. I.D.
33	092.1055	Grease Fitting—1/4 in. Straight
34	—	Drive Channel Assy.—RH
—	B-16615	24 in. Long Drive Section
—	B-16617	30 in. Long Drive Section
—	B-16619	36 in. Long Drive Section
35	—	Drive Channel Assy.—LH
—	B-16616	24 in. Long Drive Section
—	B-16618	30 in. Long Drive Section
—	B-16620	36 in. Long Drive Section
—	—	Forward Track—Drive—RH
—	B-16628-024	24 in. Long Drive Section
—	B-16628-030	30 in. Long Drive Section
—	B-16628-036	36 in. Long Drive Section
37	—	Forward Track—Drive—LH
—	B-16629-024	24 in. Long Drive Section
—	B-16629-030	30 in. Long Drive Section
—	B-16629-036	36 in. Long Drive Section
38	—	Return Track—Drive
—	B-16630-024	24 in. Long Drive Section
—	B-16630-030	30 in. Long Drive Section
—	B-16630-036	36 in. Long Drive Section
39	—	Belt Guide Block—Drive
—	B-16631-024	24 in. Long Drive Section
—	B-16631-030	30 in. Long Drive Section
—	B-16631-036	36 in. Long Drive Section
40	B-06667	Bed Spacer (Specify Belt Width)
41	—	Upper Incline Joint Plate Assembly
—	B-06949	30 Degree
—	B-06951	45 Degree
—	B-06953	60 Degree
42	—	Intermediate Channel Assy.
—	B-06687	24 in. Long
—	B-06688	48 in. Long
—	B-06689	72 in. Long
—	B-06690	96 in. Long
—	B-06691	120 in. Long
43	—	Forward Track—Intermediate
—	B-06666-024	24 in. Long

Ref. No.	Part No.	Description
—	B-0666-048	48 in. Long
—	B-06666-072	72 in. Long
—	B-06666-096	96 in. Long
—	B-06666-120	120 in. Long
44	—	Return Track—Intermediate
—	B-06659-024	24 in. Long Section
—	B-06659-048	48 in. Long Section
—	B-06659-072	72 in. Long Section
—	B-06659-096	96 in. Long Section
—	B-06659-120	120 in. Long Section
45	—	Belt Guide Block—Intermediate
—	B-06680-024	24 in. Long Section
—	B-06680-048	48 in. Long Section
—	B-06680-072	72 in. Long Section
—	B-06680-096	96 in. Long Section
—	B-06680-120	120 in. Long Section
46	—	Lower Incline Joint Plate Assembly
—	B-06378	30 Degrees
—	B-06844	45 Degrees
—	B-06845	60 Degrees
47	B-06683	Tail Shaft—1-7/16 in. Dia. (Specify Belt Width)
48	B-14959	Pulley Spacer—1.459 in. I.D. x 1-5/8 in. O.D. x 1-3/4 in. Lg.
49	010.553	Take-up Block Bearing—1-7/16 in. Bore
50	B-06669	Take-up Bolt Assembly
51	041.106	Hex Nut—3/4-10
52	B-06685	Threaded Section Spacer (Specify Belt Width)
53	—	Tail Channel Assy.—RH
—	B-06644	24 in. Long Tail Section
—	B-06646	30 in. Long Tail Section
—	B-06648	36 in. Long Tail Section
54	—	Tail Channel Assy.—LH
—	B-06645	24 in. Long Tail Section
—	B-06647	30 in. Long Tail Section
—	B-06649	36 in. Long Tail Section
55	—	Forward Track—Tail—RH
—	B-06653-24	24 in. Long Tail Section
—	B-06653-30	30 in. Long Tail Section
—	B-06653-36	36 in. Long Tail Section
56	—	Forward Track—Tail—LH
—	B-06654-24	24 in. Long Tail Section
—	B-06654-30	30 in. Long Tail Section
—	B-06654-36	36 in. Long Tail Section
57	—	Return Track—Tail
—	B-06279-24	24 in. Long Tail Section
—	B-06279-30	30 in. Long Tail Section
—	B-06279-36	36 in. Long Tail Section
58	—	Belt Guide Block—Tail
—	B-06615-24	24 in. Long Tail Section
—	B-06615-30	30 in. Long Tail Section
—	B-06615-36	36 in. Long Tail Section
59	B-06668	End Cap (Specify Belt Width)
60	—	Piano Hinge Belt
—	069.700	6 in. Wide (Specify Length)
—	069.701	8 in. Wide (Specify Length)
—	069.702	12 in. Wide (Specify Length)
—	069.703	18 in. Wide (Specify Length)
—	069.704	24 in. Wide (Specify Length)
61	G-0600	H/S Type Pivot Plate
62	—	Floor Support Frame
—	G-0888	4-1/2 in. High
—	G-0910	6 in. High
—	G-1501	9 in. High
—	B-7169	12 in. High (Specify Belt Width)
—	B-7171	15 in. High (Specify Belt Width)
—	B-7173	18 in. High (Specify Belt Width)
—	B-7179	24 in. High (Specify Belt Width)
—	B-7181	30 in. High (Specify Belt Width)
—	B-7446	42 in. High (Specify Belt Width)
—	B-7185	54 in. High (Specify Belt Width)
—	B-7187	66 in. High (Specify Belt Width)
—	B-7192	78 in. High (Specify Belt Width)
63	—	Adjustable Foot Assembly
—	B-12626	3-3/4 in. High (Specify Belt Width)
—	B-12627	5-1/8 in. High (Specify Belt Width)
—	B-12628	18-3/8 in. High (Specify Belt Width)
—	G-0613	7-3/4 in. High
—	G-0614	10-1/4 in. High
—	G-0615	18-3/8 in. High
64	—	Knee Brace Angle
—	G-00794-001	18 in. Long
—	G-00794-002	20 in. Long
—	G-00794-003	27 in. Long
—	G-00794-004	36 in. Long



HYTROL CONVEYOR COMPANY, INC.
2020 Hytrol Drive
Jonesboro, Arkansas 72401

Phone: (870) 935-3700

www.hytrol.com

www.ezlogic.com

EFFECTIVE MARCH, 1995

Printed in the USA 8/98

